

☑ Be careful with the float with Hydrogen or Alcohol compounds

☑ Hydro Test Gauge 3 min @ 320 bar
 ☑ Material Certificate EN10204 3.1

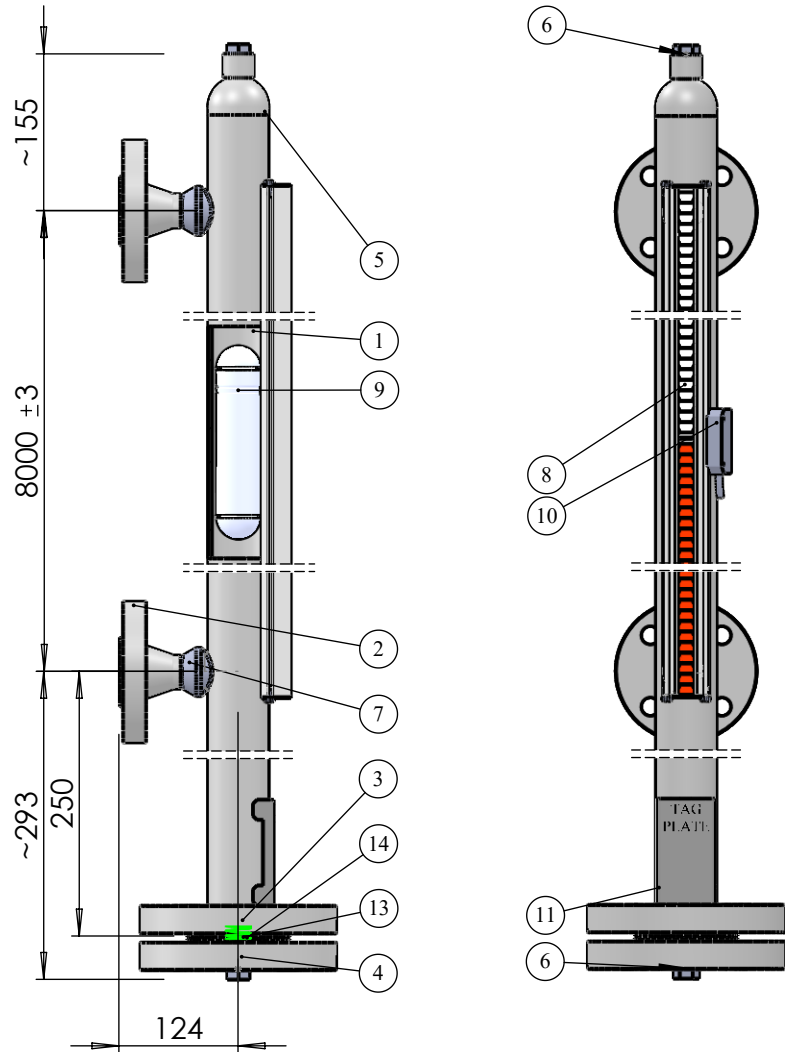

14	1	Bottom Spring	1.4401 / 1.4404
13	1	Gasket	316 Spiral wound
12	-	Bolts and Nuts	SS A2 (304)
11	1	Tag Plate	1.4401 / 1.4404
10	1	HLS-15 SPDT 10-230V AC/DC 2,5A 60W 60VA	Plastic 5m cable
9	1	Float : TXX13/3.30 Ø45x255 mm	Titanium
8	1	Indicator	Alu / Poly
7	2	Weldolet 1"	1.4401 / 1.4404
6	2	Plug 1/2" - EN/BSP	1.4401 / 1.4404
5	1	Top Endcap 2" x 3.91mm (sch40)	1.4401 / 1.4404
4	1	Bottom Flange DN 50 PN 250 B2 EN 1092-1	1.4401 / 1.4404
3	1	Bottom Flange DN 50 PN 250 B2 EN 1092-1	1.4401 / 1.4404
2	2	Process Flange DN 25 PN 250 WN B2 EN 1092-1	1.4401 / 1.4404
1	1	Measuring Tube Ø73.03 x 9.53mm	1.4401 / 1.4404
Pos.	Qty.	Description	Material

MAGNETIC LEVEL GAUGE

Type D-160

BAMO IER

Client :
 Order :
 Tag nr. :

Weight : 125 kg

S.G. : > 0.998
 Pressure : 0 / 200 bar
 Temp. : 0 / 40 °C

Date : 26-4-2023

Viscosity: < 1000 cP

Drawing nr. : 230426-01M

2014/68/EU:
 PED Cat III **CE0343**

BAMO IER GmbH Tel. +49 621 84224-0 Fax +49 621 84224-90 www.bamo.de info@bamo.de